

# The "Drive-Thru" Clearance Bar

## Model CB100



### Features:

- 6' reach over drive
- Sturdy steel construction.
- Powder coated finish.
- Auto-return bar.
- Optional light box & banner kit for added graphics.

### Benefits:

A drive-thru **Clearance Bar** will help prevent damage to your "drive-thru protective covers". Our pivoting auto-return bar provides an early warning to motorist that may have an oversize vehicle that could do damage to your drive-thru coverings.

The pivoting action reduces impact damage for both the vehicle and the clearance bar and, if hit, will pivot away from the impact and then retract back to its original position.

**Quantity discounts are available.**

### Standard Colors:

Black



Custom colors are available.

**Model CB100** ..... **\$1,285.00**  
(Std. Black Post)

### Available Options:

12" x 44" Vertical Sign Box ..... **\$325.00**  
Two Pole Banner Kit ..... **\$90.00**  
Custom Color.....**\$125.00**

All pricing is F.O.B. Ball Ground, GA

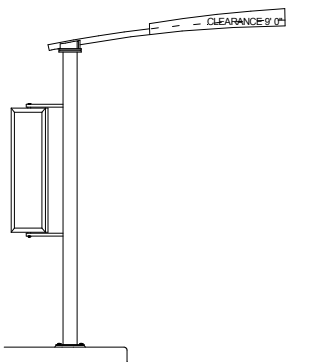

Standard Sign Box  
12" x 44" Vertical

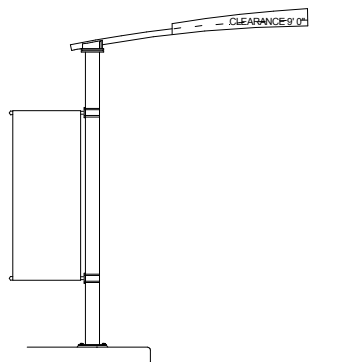

Two Pole Banner Kit  
Banner Not Included

AWNTEK, Inc.  
260 Valley Street, Suite 100, Ball Ground, GA 30107  
Ph: 770-704-7140, Fax: 770-704-7647  
www.awntek.com



## Physical Dimensions:

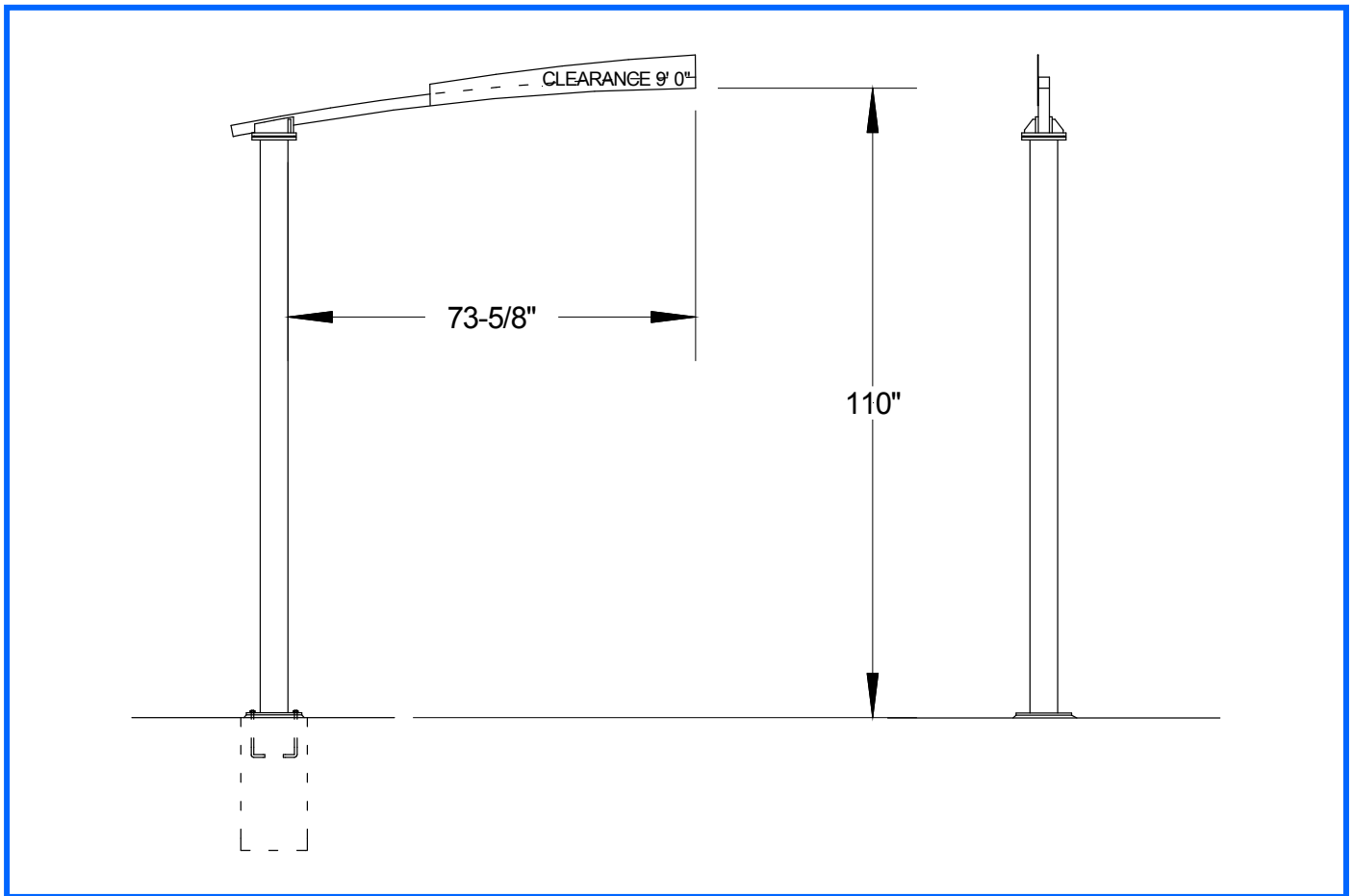

### **Shipping:**

The unit is shipped in a sturdy wood and plywood crate with a combined freight weight of only 80 lbs. (F.O.B. Ball Ground, GA)

### **Installation:**

Each unit comes with comprehensive installation instructions. The footer size should be determined by local conditions. Typically a local sign company can install this **Clearance Bar** at a reasonable cost.

### **Materials:**

Post: 5" sq x .188" wall steel tubing  
Bar: 2" sq steel tubing  
Paint: (Black - standard)  
Graphics: White reflective film

AWNTEK, Inc.  
260 Valley Street, Suite 100, Ball Ground, GA 30107  
Ph: 770-704-7140, Fax: 770-704-7647  
www.awntek.com

AWNTEK Inc.  
Architectural Enhancements